

Preliminary investigation of a gaseous fuel composition influence on spark ignition engine performance.

WŁOSTOWSKI Radosław, GÓRNIAK Aleksander, WRÓBEL Radosław, TRZMIEL Kamil

This paper constitutes a performance comparison of an engine fed with various mixture of gases which can be expected as a product of biomass gasification – i.e. hydrogen, carbon dioxide, carbon monoxide, and methane. The share of those components is dependent mainly upon the gasification process, and the gasified fuel type. For this reason the test station was design for easy change of the gas mixture composition. Here set of various 12 gas mixtures was taken into account for the evaluation of the engine power, cylinder temperature and fuel consumption. Statistically elaborated influence of the gas fuel composition on the parameters of engine performance constitutes the basis for the selection of the best engine, optimization of engine's adjustments as well as development of the control algorithm for a gasification unit.

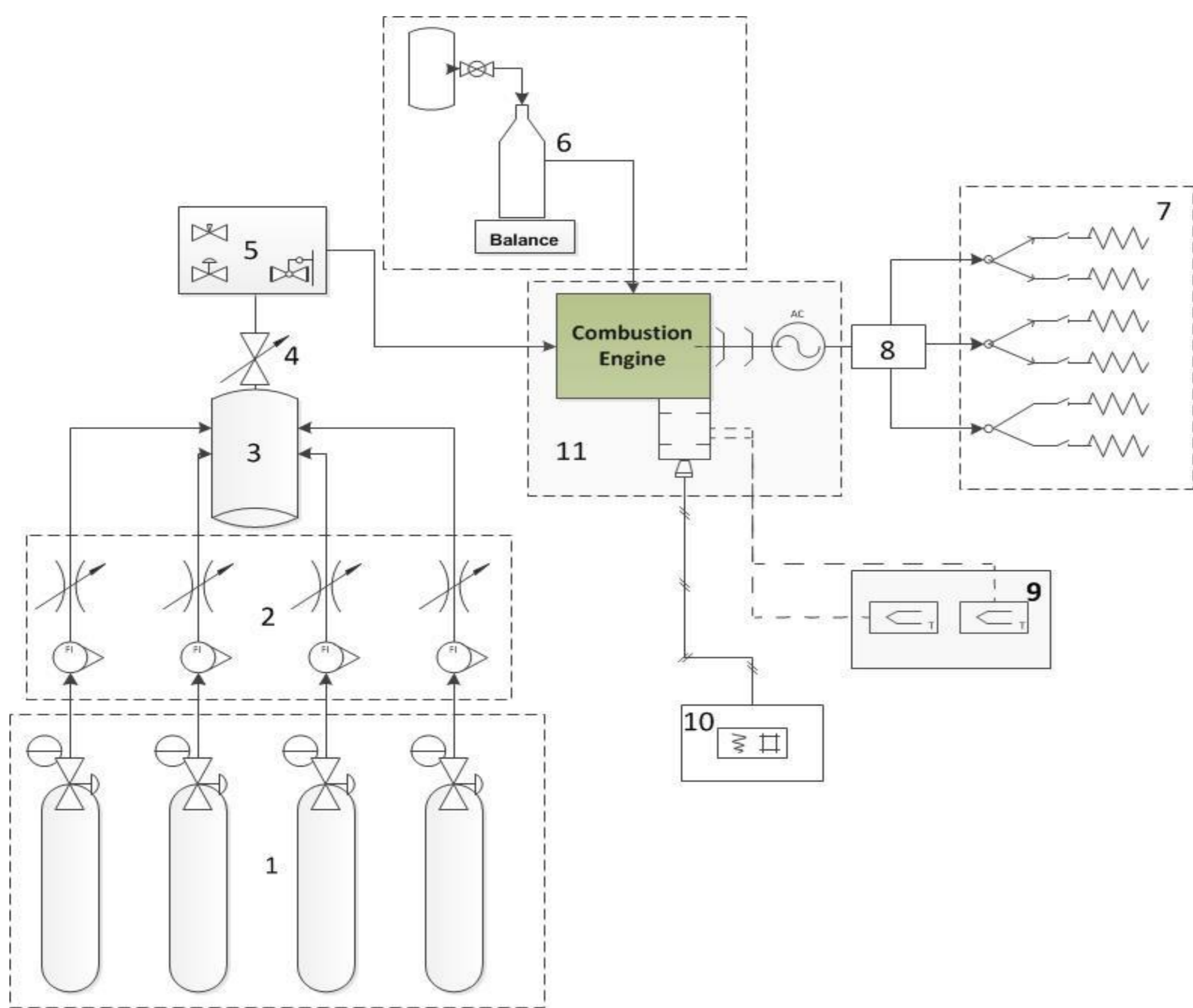

Fig. 1. Schematic representation of the test station;

1 – gas cylinders with reducers, 2 – table of rotates and control valves, 3 – gas mixer, 4 – shut-off valve of the evaporator, 5 – evaporator, 6 – system of liquid fuels consumption measurement, 7 – system of generator loading, 8 – electrical values measuring set, 9 temperature measuring system, 10 – exhaust gas analyser, 11 – power generator.

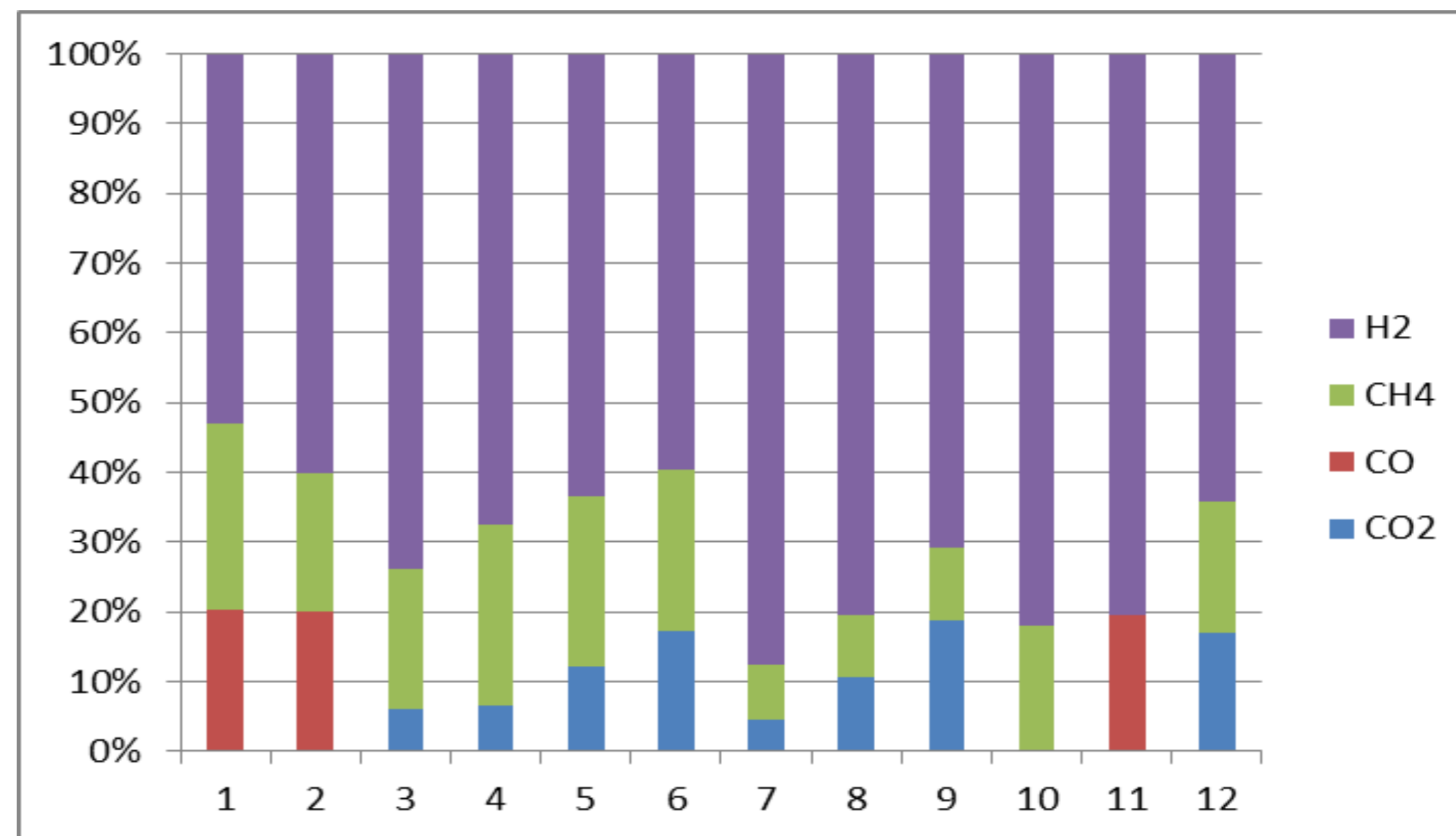

Fig. 2. Samples of a gas composition

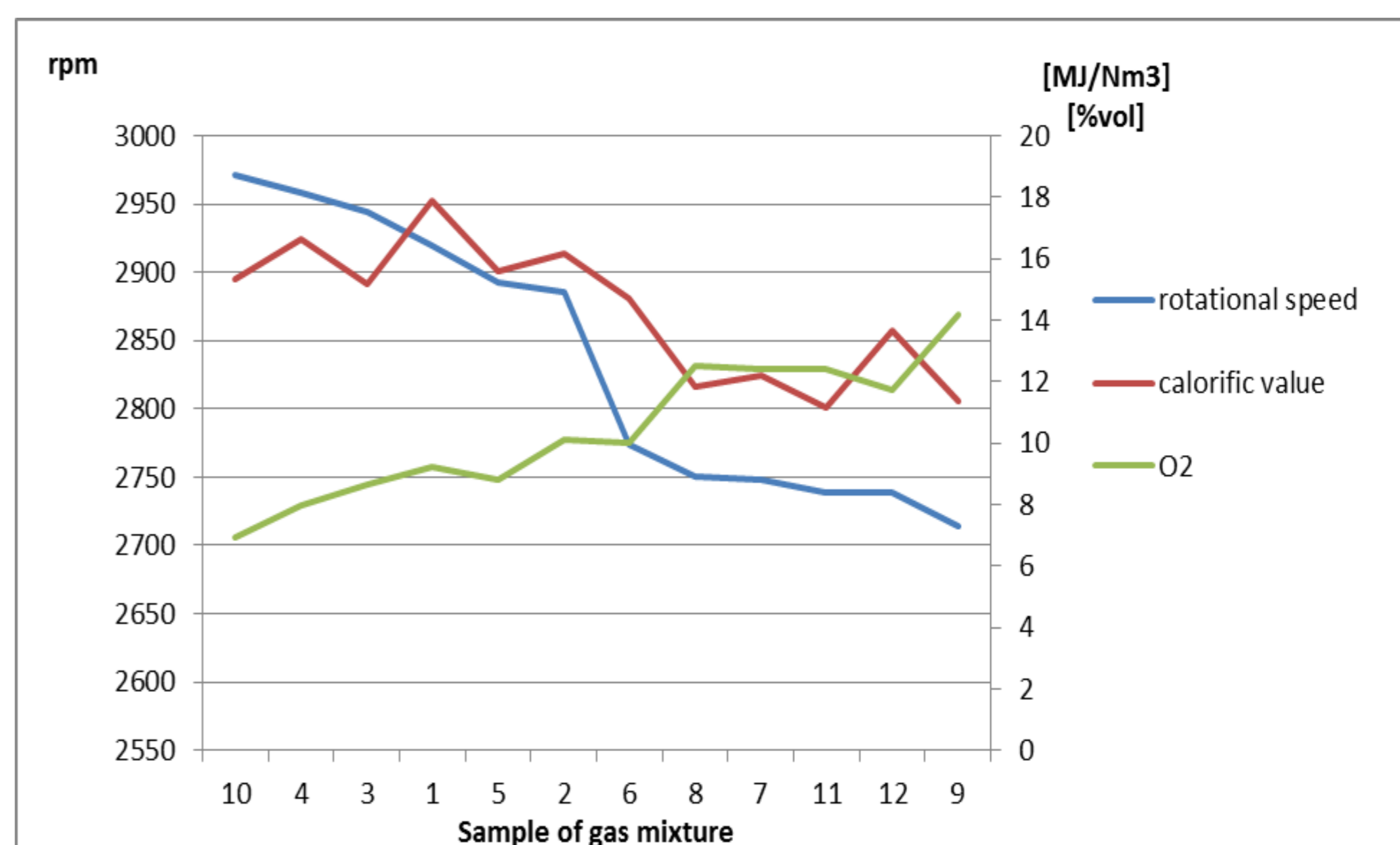

Fig. 4. Relationship of rotational speed, calorific value and oxygen emission for gaseous fuel compositions

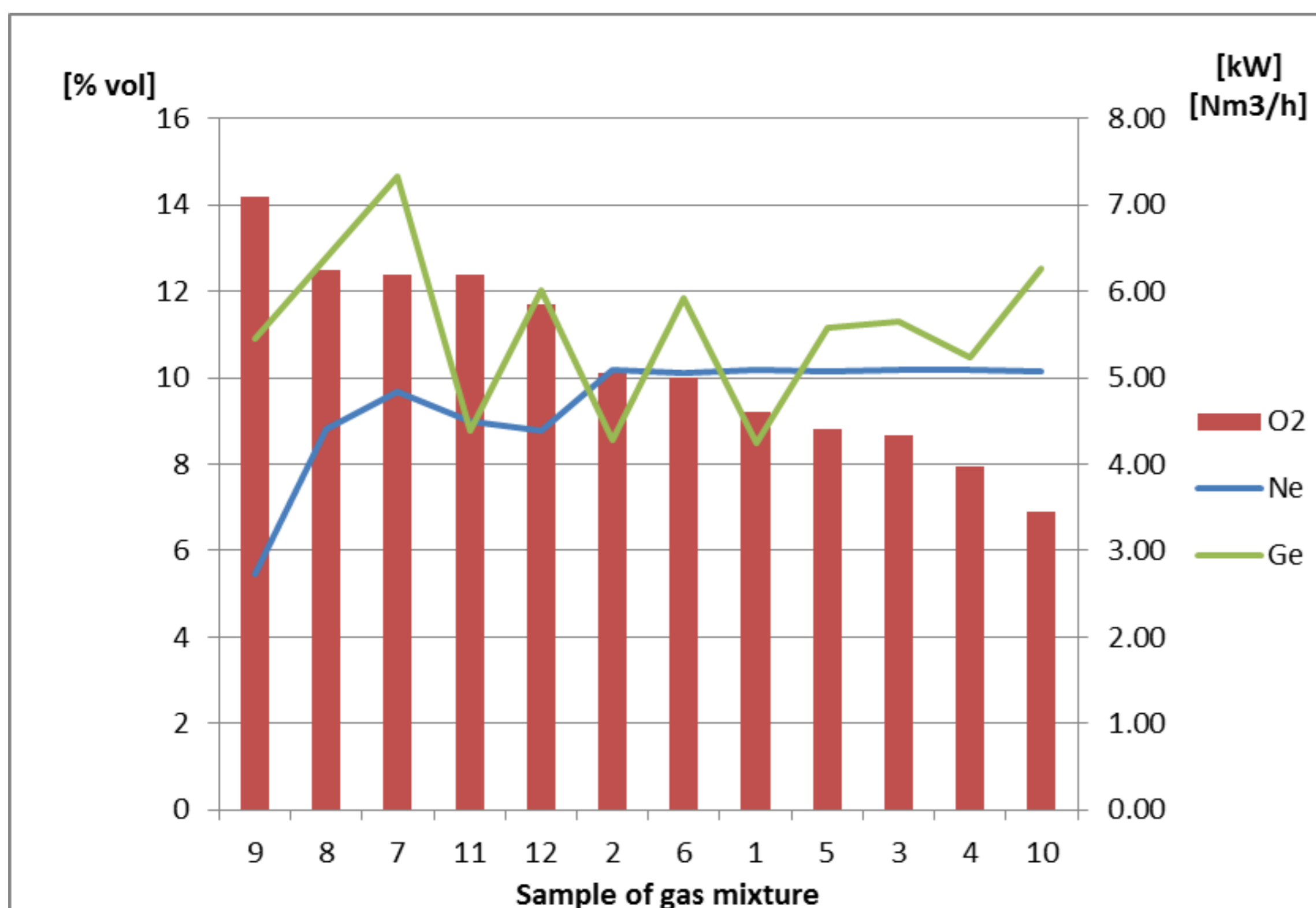

Fig. 3. Relationship of engine power and fuel consumption with respect to the oxygen emission

Conclusion

The performance of the engine fed with gaseous fuel of various composition shows the large complexity of the process. The randomness of the results forbids to precisely identify the impact of a particular gas on an engine performance. Every gas mixture represented different level of significance for engine performance as well as generated different difficulties during engine operation. For example, during the test of sample 4 an uncontrolled explosion outside the combustion chamber and ignition dislocation was detected.

For fuels with calorific values less than 15 MJ/Nm³ the engine did not reached its working parameters. This might be partially consequence of the amount of oxygen in exhaust gases because engine reached its working parameters only when the amount of oxygen in exhaust gases was greater than 10%. Furthermore, it appeared that the greater amount of oxygen in exhaust gases the greater is its temperature. The higher heating value of the fuel, the lower gas consumption.

The exception is sample 4 due to improperly extending the combustion process. It appeared that increased share of carbon in high – carbon fuels limits the speed of combustion, increasing the methane number of fuel.



Mr Radosław Włostowski, M.Eng. PhD student, Faculty of Mechanical Engineering at Wrocław University of Technology.
Mgr inż. Radosław Włostowski – doktorant, Wydział Mechaniczny Politechniki Wrocławskiej.



Mr Aleksander Górniak, DSc., DEng. – Research assistant in the Faculty of Mechanical Engineering at Wrocław University of Technology.
Dr inż. Aleksander Górniak – asystent na Wydziale Mechanicznym Politechniki Wrocławskiej.



Mr. Radosław Wróbel, PhD, eng. is a senior lecturer in the Faculty of Mechanical Engineering at Wrocław University of Technology.
Dr inż. Radosław Wróbel – adiunkt na Wydziale Mechanicznym Politechniki Wrocławskiej



Mr Kamil Trzmieł, MSc. Eng. – Faculty of Mechanical Engineering at Wrocław University of Technology.
Mgr Inż. Kamil Trzmieł – Wydział Mechaniczny Politechniki Wrocławskiej.

